

DMG MORI ALC/ALX 1500, 2000, 2500 (12ST, BMT40)

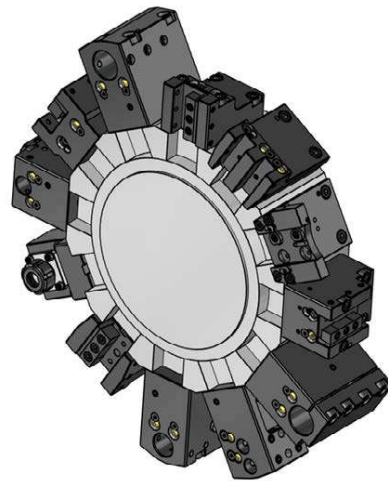

Static Toolholders - Standard Program

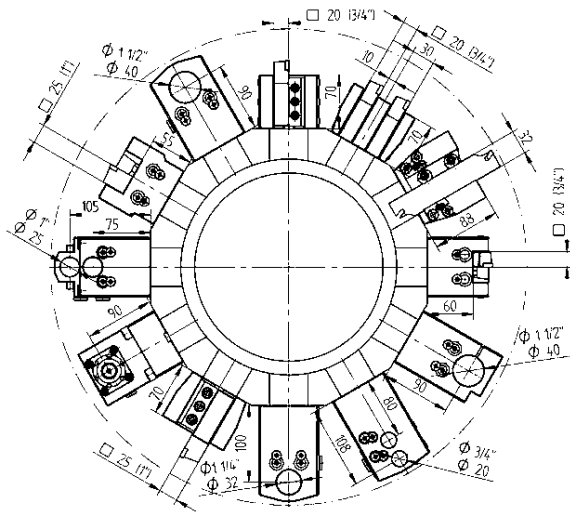

OD cutting holder, short

20	48-T00224 T00224, 5000042
25	48-T00267 T00267
3/4"	48-T00234 T00234, 5000058
1"	48-T00272 T00272



OD cutting holder, short, HP-IC

20	48-T00224-HP T00224, 5000042	IC 80 bar
25	48-T00267-HP T00267	IC 80 bar
3/4"	48-T00234-HP T00234, 5000058	IC 80 bar
1"	48-T00272-HP T00272	IC 80 bar



OD cutting holder, long

20	48-T00225 T00225, 5001565
3/4"	48-T00235 T00235, 5001572



OD cutting holder, long, HP-IC

20	48-T00225-HP T00225, 5001565	IC 80 bar
3/4"	48-T00235-HP T00235, 5001572	IC 80 bar
25	48-79462-HP	IC 80 bar

Static Toolholders - Standard Program



OD cutting holder, both sides, short

20	48-T00228 T00228, 5001569
25	48-86523
3/4"	48-T00250 T00250, 5001583
1"	48-86524



OD cutting holder, both sides, short, HP-IC

20	48-T00228-HP T00228, 5001569	IC 80 bar
25	48-86523-HP	IC 80 bar
3/4"	48-T00250-HP T00250, 5001583	IC 80 bar
1"	48-86524-HP	IC 80 bar



OD cutting holder, both sides, long

20	48-T00226 T00226, 5001567
3/4"	48-T00249 T00249, 5001581



Face cutting holder

25	48-T03024 T03024
1"	48-T03025 T03025

DMG MORI ALC/ALX 1500, 2000, 2500 (12ST, BMT40)

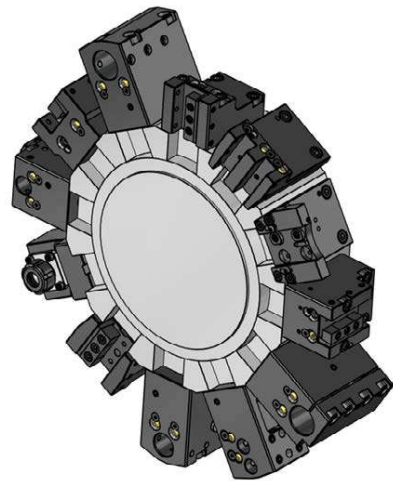
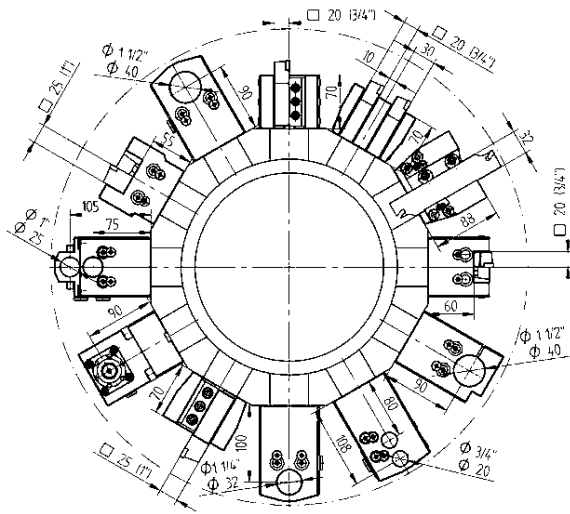

Static Toolholders - Standard Program

Static Toolholders - Standard Program



Face cutting holder, HP-IC

- | | | |
|-------------|---------------------------------|-----------|
| 20 | 48-T03017-HP
T03017, 5000043 | IC 80 bar |
| 3/4" | 48-T03018-HP
T03018, 5000059 | IC 80 bar |



Boring bar holder, both sides

- | | |
|-------------|---------------------|
| Ø 25 | 48-T10117
T10117 |
| Ø 1" | 48-T10139
T10139 |



Cut-off holder, right hand

- | | |
|-------------|-----------------------------|
| 20 | 48-T00251
T00251 |
| 25 | 48-T00268
T00268, T00356 |
| 3/4" | 48-T00252
T00252 |
| 1" | 48-T00359
T00359, T00357 |



Boring bar holder

- | | |
|-----------------|------------------------------|
| Ø 32 | 48-T10115
T10115, 5000044 |
| Ø 1 1/4" | 48-T10119
T10119, 5000060 |



ID combination holder

- | | | |
|-----------------|------------------------------|-----------|
| Ø 32 | 48-T13132
T13132, 5000045 | IC 80 bar |
| Ø 40 | 48-77999 | IC 80 bar |
| Ø 1 1/4" | 48-T13135
T13135, 5000061 | IC 80 bar |
| Ø 1 1/2" | 48-80016 | IC 80 bar |

DMG MORI ALC/ALX 1500, 2000, 2500 (12ST, BMT40)

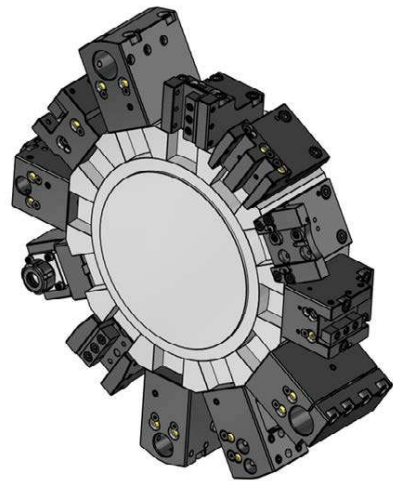
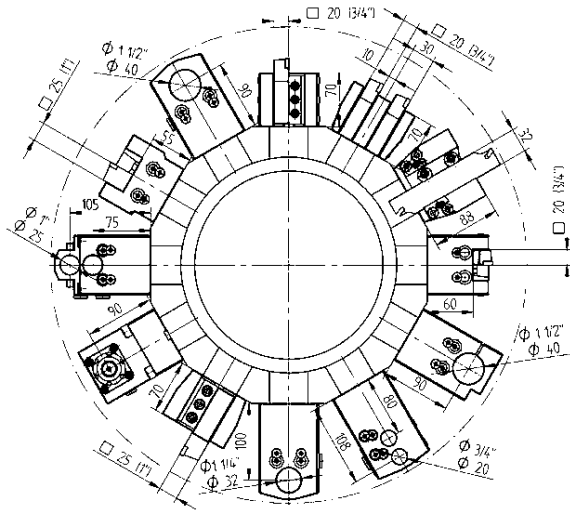



Static Toolholders - Enhanced Program

- 

OD cutting holder, double, Y axis
 20(3/4") 48-77726
- 

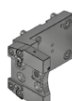
OD cutting holder, both sides, double, Y axis
 20(3/4") 48-77727
- 

Face cutting holder, both sides
 20 48-79608
 3/4" 48-79609
- 

Cut-off holder, adjustable
 SH 32 48-98891
- 

Cut-off holder, adjustable, HP-IC
 SH 32 48-102261R IC 80 bar
 SH 32 48-102261L IC 80 bar
- 

Boring bar holder, with slot
 Ø 32 48-82057
 Ø 40 48-82058
 Ø 1 1/4" 48-82059
 Ø 1 1/2" 48-82060

Static Toolholders - Enhanced Program

- 

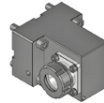
Boring bar holder, double, universal
 Ø 20 48-75406
 Ø 3/4" 48-75416
- 

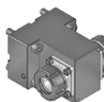
Collet face drill holder
 ER 25 48-107230 IC 80 bar
 107525000
 ER 32 48-81031 IC 80 bar
 107532000
- 

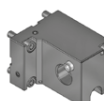
Collet face drill holder, both sides
 ER 25 48-107227 IC 80 bar
 107525000
 ER 32 48-80509 IC 80 bar
 107532000
- 

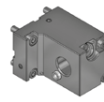
VDI adapter, left
 VDI 30 48-77732
- 

VDI adapter, right
 VDI 30 48-78687
- 

Boring bar holder, blank
 48-80506

DMG MORI ALC/ALX 1500, 2000, 2500 (12ST, BMT40)

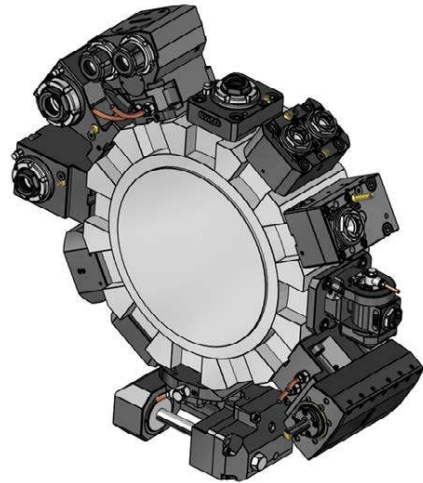
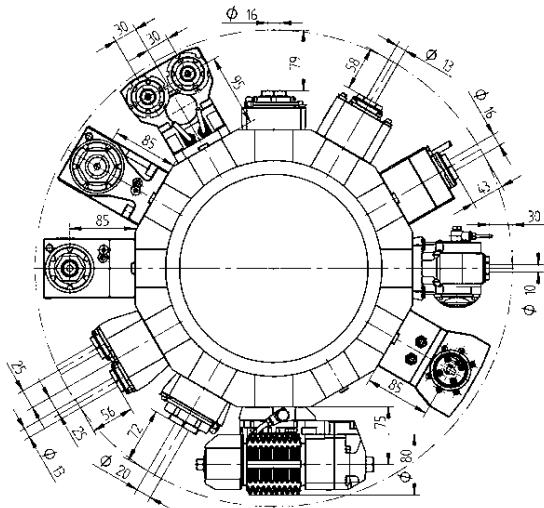

Driven Toolholders - QuickFlex®



OD drill/milling unit (12000 RPM)

ER-25 QF	420125012-40 T32433, 5002610 0067725000	1:1	EC
ER-25 QF	420125013-40 0067725000	1:1	IC 80 bar
ER-32 QF	QF32-DNE-MS40A-050-E-HS-A 0067732000	1:1	EC
ER-32 QF	QF32-DNE-MS40A-067-I-HS-A 0067732000	1:1	IC 100 bar



OD drill/milling unit (12000 RPM) - QF smart (EU, US, CA, JP)

ER-32 QF	QF32-DNE-MS40A-067-I-HS-SB-A 0067732000	1:1	IC 100 bar
	LI-F12-01		



OD drill/milling unit (6000 RPM, Heavy Duty)

ER-25 QF	420125010-40 T32274, T32450, 5002615 0067725000	1:1	EC
ER-25 QF	420125011-40 T32287, T32482, 5002629 0067725000	1:1	IC 80 bar
ER-32 QF	QF32-DNE-MS40A-050-E-A T32475, T32484, 5002631 0067732000	1:1	EC
ER-32 QF	QF32-DNE-MS40A-067-I-A 0067732000	1:1	IC 100 bar

Driven Toolholders - QuickFlex®



Face drill/milling unit (12000 RPM)

ER-25 QF	420525013-40 T32434, 5002611 0067725000	1:1	EC
ER-25 QF	420525014-40 T32436, 5002613 0067725000	1:1	IC 80 bar
ER-32 QF	QF32-DNI-MS40A-085-E-HS-A 0067732000	1:1	EC
ER-32 QF	QF32-DNI-MS40A-085-I-HS-A 0067732000	1:1	IC 100 bar



Face drill/milling unit (12000 RPM) - QF smart (EU, US, CA, JP)

ER-32 QF	QF32-DNI-MS40A-085-I-HS-SB-A 0067732000	1:1	IC 100 bar
	LI-F12-01		



Face drill/milling unit (6000 RPM, Heavy Duty)

ER-25 QF	420525010-40 T32275, T32297, 5002562 0067725000	1:1	EC
ER-25 QF	420525011-40 T32288, T32435, 5002612 0067725000	1:1	IC 80 bar
ER-32 QF	QF32-DNI-MS40A-085-E-A T32476, T32485, 5002632 0067732000	1:1	EC
ER-32 QF	QF32-DNI-MS40A-085-I-A 0067732000	1:1	IC 100 bar



Management Service

CERTIFICATE

Certificate Registration No.: **12 100 6526 TMS** / Order No.: **70006088**

The Certification Body
of TÜV SÜD Management Service GmbH

certifies that the organization

DMG MORI Pfronten GmbH
DECKEL MAHO-Straße 1
87459 Pfronten
Germany

for the scope

**Design and Manufacturing of
Universal Milling Machines, Machining Centres as well as
Automation and Digitalization Solutions**

has established and applies a Quality Management System.

An audit was performed and has furnished proof
that the requirements according to

DIN EN ISO 9001:2015

are fulfilled.

The certificate is valid from **2024-03-13** until **2026-08-01**.

Fred Wenke
Head of Certification Body
Munich, 2024-03-14



CERTIFICATE

DMG MORI

ISO 14001:2015

DEKRA Certification GmbH hereby certifies that the organization

DMG MORI AG

Gildemeisterstraße 60, 33689 Bielefeld, Germany

at the site:

DMG MORI Spare Parts GmbH

Lausitzerstraße 7, 82538 Geretsried, Germany

for the scope of certification:

Purchasing, storage, distribution and shipping of spare parts for machine tools and other group products.

has established and maintains an environmental management system according to the above mentioned standard. The conformity was adduced with audit report no. A24081344. This certificate is valid only in conjunction with the main certificate no. 170522041/1.

Certificate registration no.:	170522041/1-6
Validity of previous certificate:	2025-05-09
Certificate valid from:	2025-05-10
Certificate valid till:	2028-05-09

Language translation



Dr. Rolf Krökel
DEKRA Certification GmbH, Stuttgart, 2025-04-24



Deutsche
Akkreditierungsstelle
D-ZM-16029-01-00